



CS **n ≈ 2900 rpm**
Close coupled centrifugal pump
Bomba centrífuga acoplado cerrado
Pompe centrifuge à couple fermé

NEW/NUEVO/NOUVEAU

DESCRIPTION/DESCRIPCIONES/DESCRIPTION

- ◆ New EN733 standard centrifugal pump
 - ◆ Original design by PURITY (Patent no.201530478502.0)
 - ◆ Both square motor & round motor available
 - ◆ YE3 high efficient motor, with protection IP55 class F
 - ◆ Pump case with anti-corrosive coating
 - ◆ Galvanized counter flange with bolts, nuts and gaskets
 - ◆ Quality NSK bearing, wear resistance mechanical seal
- ◆ Nuevas bombas centrífugas según norma EN733
 - ◆ Diseño original de PURITY (Patente no.201530478502.0)
 - ◆ Motor redondo y cuadrado disponible
 - ◆ Motor de eficiencia YE3 con Protección IP55 clase F
 - ◆ Cuerpo de bomba con tratamiento anti-corrosión
 - ◆ Contrabridas galvanizadas con pernos, tuercas y empaques
 - ◆ Rodamiento de marca NSK y cierre mecánico personalizado
- ◆ Nouvelle pompe centrifuge standard EN733
 - ◆ Design original par PURITY (Brevet no.201530478502.0)
 - ◆ Moteur carré et moteur rond disponibles
 - ◆ Moteur haute efficacité YE3, avec protection IP55 classe F
 - ◆ Boîtier de pompe avec revêtement anti-corrosif
 - ◆ Contre-bride galvanisée avec boulons, écrous et joints
 - ◆ Roulement NSK qualité, joint mécanique de résistance à l'usure

APPLICATIONS/APLICACIONES/APPLICATIONS

- ◆ Suitable for use with clean water and liquids that are not chemically aggressive towards the materials from which the pump is made. The EN733 centrifugal pumps are recommended for use in water supply, cleaning sets, pressure boosting, firefighting sets, irrigation, industrial applications, water circulation in climatisation sets, agricultural.
- ◆ Son recomendadas para bombear agua limpia, sin partículas abrasivas y líquidos químicamente no agresivos con los materiales que constituyen la bomba. Las Bombas centrífugas según EN733 diseñadas para abastecimiento hídrico, instalaciones de lavado, presurización, contra incendio, irrigación, industria, circulación del agua, agricultura.
- ◆ Convient pour une utilisation avec de l'eau propre et des liquides qui ne sont pas chimiquement agressif envers les matériaux dont la pompe est faite. Les pompes centrifuges EN733 sont recommandées pour une utilisation dans l'alimentation en eau, kits de nettoyage, boosters de pression, kits anti-incendie, irrigation, industriels applications, circulation de l'eau dans les groupes de climatisation, agricole.

USING LIMITS/LÍMITES UTILIZACIÓN/UTILISATION LIMITES

- ◆ Liquid temperature between -10°C and +120°C
- ◆ Ambient temperature between -10°C and +50°C
- ◆ Max. working pressure **16 bar**
- ◆ Continuous service **S1**
- ◆ Temperatura del líquido de -10 °C hasta +120 °C
- ◆ Temperatura ambiente de -10 °C hasta +50 °C
- ◆ Presión máxima en el cuerpo de la bomba **16 bar**
- ◆ Funcionamiento continuo **S1**
- ◆ Température du liquide entre -10 °C et +120 °C
- ◆ Température ambiante entre -10 °C et +50 °C
- ◆ Max. pression de service **16 bar**
- ◆ Service continu **S1**

TECHNICAL DATA/DATOS TÉCNICOS/DONNÉES TECHNIQUES
50 Hz n=2900 1/min

MODEL MODELO MODÈLE	DN mm	Power Potencia Puissance kw hp		Q=DELIVERY/CAUDAL/DÉBIT																		
				H=Head/Altura/Hauteur(m)																		
				us gpm 0	26	40	66	79	106	119	159	185	211	238	317	370	396	476	529	608		
l/min0	100	150	250	300	400	450	600	700	800	900	1200	1400	1500	1800	2000	2300						
m ³ /h0	6	9	15	18	24	27	36	42	48	54	72	84	90	108	120	138						
CS 32-125/0.75	50x32	0.75	1	17.5	16.7	15	12	9	-	-	-	-	-	-	-	-	-	-	-	-		
CS 32-125/1.1	50x32	1.1	1.5	22	21	19.7	16.5	14.5	9	-	-	-	-	-	-	-	-	-	-	-		
CS 32-160/1.5	50x32	1.5	2	25.4	23.7	22.5	18.5	15.8	-	-	-	-	-	-	-	-	-	-	-	-		
CS 32-160/2.2	50x32	2.2	3	31	29.6	28.5	24.5	22	15	-	-	-	-	-	-	-	-	-	-	-		
CS 32-160/3.0	50x32	3	4	35	34.3	32.5	28	25.5	19	15	-	-	-	-	-	-	-	-	-	-		
CS 32-200/3.0	50x32	3	4	44.2	42	39.8	35.2	32.2	24.6	19.8	-	-	-	-	-	-	-	-	-	-		
CS 32-200/4.0	50x32	4	5.5	54.5	52	50	45.5	42.3	35	30.3	-	-	-	-	-	-	-	-	-	-		
CS 32-250/5.5	50x32	5.5	7.5	60	59.5	59	55	50.2	34.5	-	-	-	-	-	-	-	-	-	-	-		
CS 32-250/7.5	50x32	7.5	10	69.5	69	68.5	66	63	53	-	-	-	-	-	-	-	-	-	-	-		
CS 32-250/9.2	50x32	9.2	12.5	75	75	74.5	72	69	59	-	-	-	-	-	-	-	-	-	-	-		
CS 32-250/11	50x32	11	15	90	89.5	88	82	78	66	-	-	-	-	-	-	-	-	-	-	-		
CS 32-250/15	50x32	15	20	97	96.5	96	90	86	73	-	-	-	-	-	-	-	-	-	-	-		
CS 32-250/5.5	50x32	5.5	7.5	79.5	74.7	71.8	63	56	37.5	-	-	-	-	-	-	-	-	-	-	-		
CS 32-250/7.5	50x32	7.5	10	95	93	91	83	76	57.8	-	-	-	-	-	-	-	-	-	-	-		
CS 40-125/1.1	65x40	1.1	1.5	14.7	-	-	-	13	11.5	10.1	5.8	-	-	-	-	-	-	-	-	-		
CS 40-125/1.5	65x40	1.5	2	18.1	-	-	-	17	15	13.9	10	6	-	-	-	-	-	-	-	-		
CS 40-125/2.2	65x40	2.2	3	24.5	-	-	-	23.2	21.5	20.2	16	13	8.3	-	-	-	-	-	-	-		
CS 40-160/3.0	65x40	3	4	31.8	-	-	-	29.5	27.5	26.3	21.5	17.5	-	-	-	-	-	-	-	-		
CS 40-160/4.0	65x40	4	5.5	38	-	-	-	36	34	33	28.5	25	20.1	-	-	-	-	-	-	-		
CS 40-200/5.5	65x40	5.5	7.5	46	-	-	-	43.8	41.3	40.1	35	30	-	-	-	-	-	-	-	-		
CS 40-200/7.5	65x40	7.5	10	57	-	-	-	53.6	51.5	50	45	41	36.5	-	-	-	-	-	-	-		
CS 40-250/9.2	65x40	9.2	12.5	64	-	-	-	59	56.5	55	49.5	45	39.8	-	-	-	-	-	-	-		
CS 40-250/11	65x40	11	15	72	-	-	-	67.5	65	63.5	57.5	52.2	47	-	-	-	-	-	-	-		
CS 40-250/15	65x40	15	20	84.5	-	-	-	79.3	77.3	75.2	70	66	61	-	-	-	-	-	-	-		
CS 40-250/18.5	65x40	18.5	25	90	-	-	-	85.5	82.8	80.7	75.8	70.5	66.5	-	-	-	-	-	-	-		
CS 50-125/2.2	65x50	2.2	3	17	-	-	-	-	-	-	15.4	14	12.8	11.5	6.5	-	-	-	-	-		
CS 50-125/3.0	65x50	3	4	20	-	-	-	-	-	-	18.8	18	17	15.6	11	-	-	-	-	-		
CS 50-125/4.0	65x50	4	5.5	24	-	-	-	-	-	-	23.1	23	21.5	20.3	15.8	11.8	-	-	-	-		
CS 50-160/5.5	65x50	5.5	7.5	32	-	-	-	-	-	-	30.6	30	28	26.6	20.5	14.8	-	-	-	-		
CS 50-160/7.5	65x50	7.5	10	40	-	-	-	-	-	-	38	37	36	34.4	29	24	21	-	-	-		
CS 50-200/9.2	65x50	9.2	12.5	50.5	-	-	-	-	-	-	46.8	45	43	40.9	32.5	26.7	-	-	-	-		
CS 50-200/11	65x50	11	15	57.5	-	-	-	-	-	-	53.5	52	50	47.5	40	34	29	-	-	-		
CS 50-200/15	65x50	15	20	62	-	-	-	-	-	-	58	56.5	54.5	52	44.5	39	35.5	-	-	-		
CS 50-250/15	65x50	15	20	68.5	-	-	-	-	-	-	64	63	61.5	59	50	41	-	-	-	-		
CS 50-250/18.5	65x50	18.5	25	79	-	-	-	-	-	-	75.8	74.8	74	71.5	63.5	55.5	47	-	-	-		
CS 50-250/22	65x50	22	30	89.5	-	-	-	-	-	-	86	85.3	84	81.5	73.5	63.5	57	-	-	-		
CS 65-125/4.0	80x65	4	5.5	19	-	-	-	-	-	-	-	-	17.3	16.8	14.5	13	11.8	-	-	-		
CS 65-125/5.5	80x65	5.5	7.5	23	-	-	-	-	-	-	-	-	21.3	20.9	19	17.5	16.7	13.7	-	-		
CS 65-125/7.5	80x65	7.5	10	27	-	-	-	-	-	-	-	-	26	25.6	24.5	23	22.5	20	18	-		
CS 65-160/9.2	80x65	9.2	12.5	33	-	-	-	-	-	-	-	-	-	31.5	30	28	27.1	24	21.5	-		
CS 65-160/11	80x65	11	15	36	-	-	-	-	-	-	-	-	-	34.5	33	31.5	30.8	28	25.5	-		
CS 65-160/15	80x65	15	20	42	-	-	-	-	-	-	-	-	-	41	40	38.5	37.8	35	33	29.5		
CS 65-200/15	80x65	15	20	45	-	-	-	-	-	-	-	-	-	45.5	43	41	40.2	36.5	34	-		
CS 65-200/18.5	80x65	18.5	25	52	-	-	-	-	-	-	-	-	-	52.3	51	49	48.2	44.5	42	-		
CS 65-200/22	80x65	22	30	59	-	-	-	-	-	-	-	-	-	59.5	58	56	55	52	49.5	44.5		
CS 65-250/22	80x65	22	30	64.8	-	-	-	-	-	-	-	-	-	64.7	62	60	58.5	53	50	-		
CS 65-250/30	80x65	30	40	80	-	-	-	-	-	-	-	-	-	79.8	77.5	75.5	74.5	70	66	58		
CS 65-250/37	80x65	37	50	92	-	-	-	-	-	-	-	-	-	90.5	88.5	87	85	80.5	78	68		

TECHNICAL DATA/DATOS TÉCNICOS/DONNÉES TECHNIQUES
50 Hz n=2900 1/min

MODEL MODELO MODÈLE	DN mm	Power Potencia Puissance		Q=DELIVERY/CAUDAL/DÉBIT													
		kw	hp	us	264	396	529	634	793	881	925	969	1057	1233	1322	1586	1762
				gpm	l/min	m ³ /h	0	1000	1500	2000	2400	3000	3333	3500	3667	4000	4667
				H=Head/Altura/Hauteur(m)													
CS 65-315/45	80x65	45	60	102	98	94.5	90	83	-	-	-	-	-	-	-	-	-
CS 65-315/55	80x65	55	75	122	120	114.5	110	100	76	-	-	-	-	-	-	-	-
CS 65-315/75	80x65	75	100	141	141	134.5	130	120	96	78	65.5	-	-	-	-	-	-
CS 65-315/90	80x65	90	125	151	150	144.5	140	130	106	88	75.5	-	-	-	-	-	-
CS 80-125/4.0	100x80	4	5.5	17	15	12.3	7.5	-	-	-	-	-	-	-	-	-	-
CS 80-125/5.5	100x80	5.5	7.5	21	19.6	17.4	13.4	9.5	-	-	-	-	-	-	-	-	-
CS 80-125/7.5	100x80	7.5	10	26	24.8	23	19.5	16.5	-	-	-	-	-	-	-	-	-
CS 80-160/11	100x80	11	15	28	27	27.3	24.5	21.1	16	-	-	-	-	-	-	-	-
CS 80-160/15	100x80	15	20	34	32.6	32.5	30.2	27	22.1	18.5	16.7	-	-	-	-	-	-
CS 80-160/18.5	100x80	18.5	25	39	38.5	38	36.7	33.6	28.8	25.3	23.5	-	-	-	-	-	-
CS 80-160/22	100x80	22	30	44	43.5	43	41.7	38.6	33.8	30.3	28.5	-	-	-	-	-	-
CS 80-200/22	100x80	22	30	48	47.7	47.5	43.5	39.2	32.5	27.2	24.5	-	-	-	-	-	-
CS 80-200/30	100x80	30	40	60	59.7	59.5	57	53.1	47	42.7	40.5	-	-	-	-	-	-
CS 80-250/37	100x80	37	50	71.5	70.9	70.5	65.5	59.3	51	43.2	38.5	-	-	-	-	-	-
CS 80-250/45	100x80	45	60	88	86.7	86	83.6	78.5	70.5	60	51	-	-	-	-	-	-
CS 80-250/55	100x80	55	75	94.5	94.5	94.5	91.8	87	79.5	72.1	68.3	-	-	-	-	-	-
CS 80-315/45	100x80	45	60	85	84	82.6	82	78	68.3	61	56	-	-	-	-	-	-
CS 80-315/55	100x80	55	75	98	97	95.6	95	91	81.3	74	69	-	-	-	-	-	-
CS 80-315/75	100x80	75	100	124	123	121.6	121	117	107.3	100	95	90	80.8	-	-	-	-
CS 80-315/90	100x80	90	125	144	143	141.6	141	137	127.3	120	115	110	100.8	-	-	-	-
CS 100-160/15	125x100	15	20	35	33.5	32.5	30	27.8	24.5	21.5	20	18.3	15	-	-	-	-
CS 100-160/18.5	125x100	18.5	25	38.5	37.5	36.5	34.3	32.2	29	25.7	24	22	18	-	-	-	-
CS 100-160/22	125x100	22	30	43	41	40	37.6	35.2	31.5	28.5	27	25.3	22	-	-	-	-
CS 100-200/22	125x100	22	30	38.5	36.7	35.7	33.8	31.7	28.5	26.8	26	25	22.9	16.3	13	-	-
CS 100-200/30	125x100	30	40	44.5	42.5	42	40.2	38.8	36.7	34.2	33	31.7	29	21.7	18	-	-
CS 100-200/37	125x100	37	50	55	53	51	50.6	49.2	47	45	44	42.8	40.5	32.8	29	-	-
CS 100-250/45	125x100	45	60	65	65	64	63	61	58	56	55	53.3	50	39	33.5	-	-
CS 100-250/55	125x100	55	75	77	76	75.5	75	73.8	72	71.7	71.5	70.7	69	62.3	59	-	-
CS 100-250/75	125x100	75	100	91	91	90.5	89.7	88	85.5	84	83.3	81.5	78	71.7	68.5	48	-
CS 100-250/90	125x100	90	125	100	100	99.5	98.7	97	94.5	93	92.3	90.5	87	80.7	77.5	57	-
CS 100-315/75	125x100	75	100	80	-	-	78.5	76.7	74	73	72.8	72.5	70.7	68	64	52	-
CS 100-315/90	125x100	90	125	100	-	-	98.5	96.7	94	93	92.8	92.5	90.7	88	84	72	-
CS 100-315/110	125x100	110	150	118	-	-	116.5	114.7	112	111	110.8	110.5	108.7	106	102	90	-
CS 100-315/132	125x100	132	180	129	-	-	127.5	125.7	123	122	121.8	121.5	119.7	117	112	101	-
CS 100-315/160	125x100	160	220	148	-	-	146.5	144.7	142	141	140.8	140.5	138.7	136	132	120	-
CS 125-200/45	150x125	45	60	39.8	-	-	39.3	39.2	39	38.9	38.9	38.8	37.5	35	34	28.6	25
CS 125-200/55	150x125	55	75	50.5	-	-	49.3	49.2	49	48.9	48.9	48.8	47.5	45	44	38.6	35
CS 125-200/75	150x125	75	100	61.5	-	-	60.3	60.2	60	59.9	59.9	59.8	58.5	56	55	49.6	46
CS 125-250/55	150x125	55	75	70	-	-	67	66	64	63	62	61	59.5	54	50.5	-	-
CS 125-250/75	150x125	75	100	80	-	-	76.5	75.5	74	73	72	71.5	70	67	65	56	-
CS 125-250/90	150x125	90	125	87	-	-	84	82.5	81	79.5	79	78	77	73.5	71.5	65	60

MATERIAL DESCRIPTION/DESCRIPCIÓN DE MATERIAL/DESCRIPTION DU MATÉRIEL

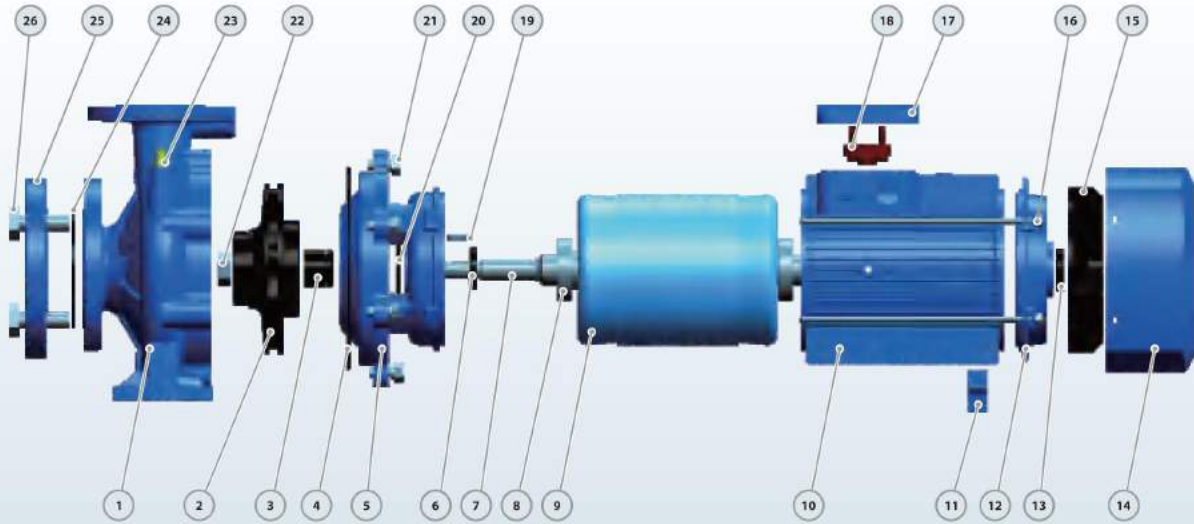

No.	Description Descripción Description	Material Material Matériel	No.	Description Descripción Description	Material Material Matériel	No.	Description Descripción Description	Material Material Matériel
1	Pump Case Cuerpo de Bomba Boîtier de pompe	Cast iron Fundición Fonte	10	Motor Case Cuerpo de Motor Boîtier du moteur	Aluminum Aluminio Aluminium	19	Impeller Key Chaveta Impulsor Clé de roue	Iron Hierro Le fer
2	Impeller Impulsor Roue	SS304/Cast iron Inox304/Fundición Inox304/ Fonte	11	Support Foot Soporte Pie Pied de support	Plastic Plástico Plastique	20	Water Deflector Deflector Déflecteur d'eau	Rubber Caucho Caoutchouc
3	Mechanical Seal Cierre Mecánico Garniture mécanique	SiC/Carbon/SS304 SiC/Grafito/Inox304 SiC/Carbon/Inox304	12	Back Cover Tapa Trasera Quatrième de couverture	Cast iron Fundición Fonte	21	Connection Bolt Perno Boulon de connexion	Steel Acero Acier
4	O-ring Junta Tórica Joint torique	Rubber Caucho Caoutchouc	13	Reinforced Seal Sello Reforzado Joint renforcé	Rubber Caucho Caoutchouc	22	Impeller Nut Tuerca de impulsor Écrou de roue	Galvanized Steel Acero Galvanizado Acier Galvanisé
5	Connection Conexión Lien	Cast iron Fundición Fonte	14	Fan Cover Tapa Ventilador Couvercle de ventilateur	Aluminum Aluminio Aluminium	23	Release Valve Tapón Cebado Soupape de décharge	Brass Bronce Laiton
6	Reinforced Seal Sello Reforzado Joint renforcé	Rubber Caucho Caoutchouc	15	Fan Ventilador Ventilateur	Plastic Plástico Plastique	24	Gasket Empaque Joint	Rubber Caucho Caoutchouc
7	Shaft Eje Arbre	SS304/45# Steel Inox 304/45# Hierro Inox304/45 #Acier	16	Through Bolt Perno Traversant le boulon	Steel Acero Acier	25	Counter Flange Contra Brida Contre bride	Galvanized Cast iron Fundición Galvanizado Fonte Galvanisée
8	Bearing Rodamiento Palier	Ball Bearing Bola Rodamiento Roulement à billes	17	Terminal Box Caja de Bornas Boîte à bornes	Aluminum Aluminio Aluminium	26	Flange Bolt Perno de Brida Boulon à bride	Steel Acero Acier
9	Wound Stator/Rotor Estator / Rotor Stator / Rotor blessure	Silicon Steel/Copper Acero al Silicio/Cobre Acier au silicium/Cuivre	18	Terminal Board Tablero de Bornas Terminal Board	Plastic Plástico Plastique			

DIMENSIONS AND WEIGHT/DIMENSIONES Y PESOS/DIMENSIONS ET POIDS

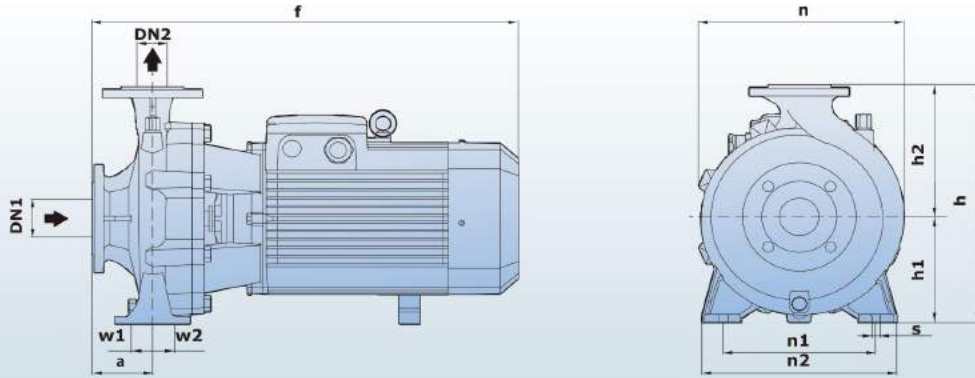

MODEL MODELO MODÈLE	DIMENSIONS/DIMENSIONES/DIMENSIONS mm													kg 3~		
	DN1	DN2	a	f	h	h1	h2	n	n1	n2	w1	w2	s			
CS 32-125/0.75	50	32	80	435	255	114	141	202	140	190	35	35	15	24		
CS 32-125/1.1			83	435	295	133	162	245	190	245				39		
CS 32-160/1.5			83	470										50		
CS 32-160/2.2					82	490	342	161	181	265	190	240				52
CS 32-200/3.0																53
CS 32-200/4.0																66
CS 32-250/5.5																73
CS 32-250/7.5					88	590	405	186	219	333	250	328	49	49	16	80
CS 32-250/9.2																95
CS 32-250/11																125
CS 32-250/15					94	712	415	186	229	327	250	327				160
CS 32-250/5.5-7.5					160	610	362	162	200	330	216	280			14	73/80
CS 40-125/1.1	65	40	82	440	260	116	144	220	160	212	37	37		27		
CS 40-125/1.5														29		
CS 40-125/2.2														34		
CS 40-160/3.0					80	490	305	135	170	250	190	241				48
CS 40-160/4.0																50
CS 40-200/5.5-7.5					102	560	345	162	193	282	214	267				66/73
CS 40-250/9.2																100
CS 40-250/11																116
CS 40-250/15					94	712	415	186	229	327	250	327	49	49		146
CS 40-250/18.5																155
CS 50-125/2.2			65	50	102	525	305	135	170	263	190	245	37	37	15	41
CS 50-125/3.0																50
CS 50-125/4.0											52					
CS 50-160/5.5-7.5					110	560	348	164	193	270	212	262				64/71
CS 50-200/9.2					104	722	392	186	206	307	232	310				90
CS 50-200/11																106
CS 50-200/15																145
CS 50-250/15-18.5-22					102	720	416	186	230	330	250	327				148/153/183
CS 65-125/4.0	80	65			104	580	345	162	193	275	212	280	49	49		56
CS 65-125/5.5-7.5																68/74
CS 65-160/9.2																
CS 65-160/11							110	730	425	186	239	330	232	309		
CS 65-160/15																134
CS 65-200/15-18.5-22					111	740										140/145/185
CS 80-125/4.0	100	80	117	750	357	163	194	330	212	280				56		
CS 80-125/5.5-7.5															68/74	
CS 80-160/11					88	750	435	186	250	330	255	332				113
CS 80-160/15-18.5-22																143/150/183
CS 100-160/15-18.5-22	125	100	130	765	435	186	250	345	262	340	55	55	16	143/150/183		

DIMENSIONS AND WEIGHT/DIMENSIONES Y PESOS/DIMENSIONS ET POIDS

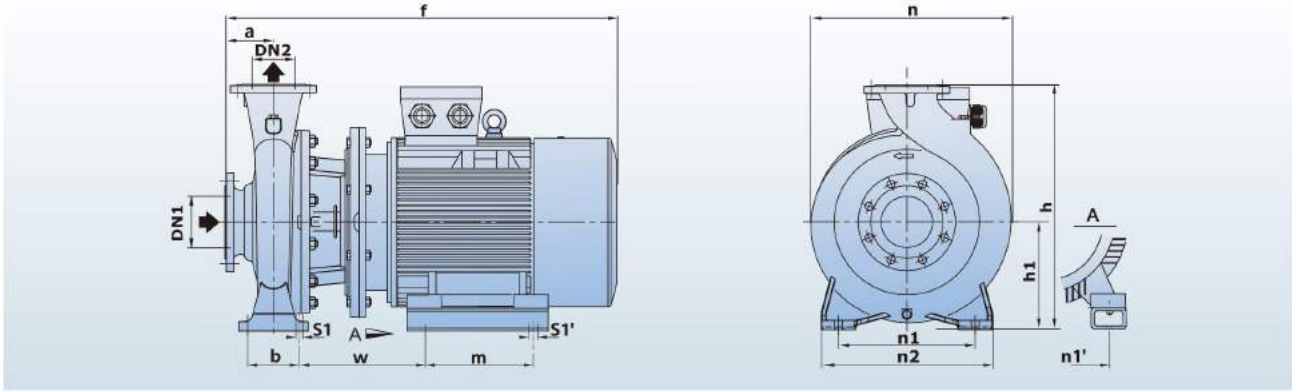

MODEL MODELO MODÈLE	DIMENSIONS/DIMENSIONES/DIMENSIONS mm															kg 3~
	DN1	DN2	a	f	h	h1	n	n1	n1'	n2	b	w	m	s1	s1'	
CS 65-250/22	80	65	116	870	420	180	369	280	279	360	120	237	241	18	15	214
CS 65-250/30	80	65	116	990	420	180	369	280	318	360	120	278	305	18	18	265
CS 65-250/37	80	65	116	990	420	180	369	280	318	360	120	278	305	18	18	285
CS 65-315/45	80	65	125	1069	505	225	440	280	356	360	120	324	311	18	18	371
CS 65-315/55	80	65	125	1160	505	225	440	280	406	360	120	373	349	18	24	450
CS 65-315/75	80	65	125	1232	505	225	440	280	457	360	120	395	368	18	24	582
CS 65-315/90	80	65	125	1283	505	225	440	280	457	360	120	395	419	18	24	617
CS 80-200/22	100	80	125	880	460	250	360	280	279	345	95	251	241	14	15	211
CS 80-200/30	100	80	125	950	460	250	360	280	318	345	95	242	305	14	18	262
CS 80-250/37	100	80	125	950	535	250	410	315	318	400	120	229	305	18	18	289
CS 80-250/45	100	80	125	980	535	250	410	315	356	400	120	235	311	18	18	362
CS 80-250/55	100	80	125	1160	535	250	410	315	406	400	120	373	349	18	24	441
CS 80-315/45	100	80	125	1069	565	250	452	315	356	400	120	324	311	18	18	381
CS 80-315/55	100	80	125	1160	565	250	452	315	406	400	120	373	349	18	24	460
CS 80-315/75	100	80	125	1232	565	250	452	315	457	400	120	395	368	18	24	592
CS 80-315/90	100	80	125	1283	565	250	452	315	457	400	120	395	419	18	24	627
CS 100-200/22	125	100	125	910	530	225	422	280	279	360	120	268	241	18	15	216
CS 100-200/30	125	100	125	1025	530	225	422	280	318	360	120	304	305	18	18	267
CS 100-200/37	125	100	125	1025	530	225	422	280	318	360	120	304	305	18	18	287
CS 100-250/45	125	100	140	1000	580	250	450	315	356	400	120	240	311	18	18	366
CS 100-250/55	125	100	140	1180	580	250	450	315	406	400	120	378	349	18	24	445
CS 100-250/75	125	100	140	1250	580	250	450	315	457	400	120	398	368	18	24	577
CS 100-250/90	125	100	140	1300	580	250	422	315	457	400	120	397	419	18	24	612
CS 100-315/75	125	100	140	1262	625	250	480	315	457	400	120	410	368	19	24	591
CS 100-315/90	125	100	140	1313	625	250	480	315	457	400	120	410	419	19	24	626
CS 100-315/110	125	100	140	1474	625	250	480	315	508	400	120	436	406	19	28	972
CS 100-315/132	125	100	140	1584	625	250	480	315	508	400	120	436	457	19	28	1087
CS 100-315/160	125	100	140	1584	625	250	480	315	508	400	120	436	508	19	28	1125
CS 125-200/45	150	125	140	1099	565	250	422	315	356	400	120	339	311	19	18	378
CS 125-200/55	150	125	140	1190	565	250	422	315	406	400	120	388	349	19	24	457
CS 125-200/75	150	125	140	1262	565	250	422	315	457	400	120	410	368	19	24	589
CS 125-250/55	150	125	140	1190	605	250	500	315	406	400	120	388	349	19	24	457
CS 125-250/75	150	125	140	1262	605	250	500	315	457	400	120	410	368	19	24	589
CS 125-250/90	150	125	140	1313	605	250	500	315	457	400	120	410	419	19	24	624